

# Gwneuthuriad Dyfrdyllau Cyflenwi Dŵr a Blaenwaith

## CANLLAWIAU AR GYFER YMARFER DA

Paratöwyd y canllawiau rhain gan Asiantaeth yr Amgylchedd (yr Asiantaeth) er mwyn tynnu sylw at ymarfer da a gwael wrth lleoli, adeiladu a chwblhau dyfrdyllau cyflenwi dŵr.

### At bwy yr anelir y canllawiau rhain?

Bwriedir i'r canllawiau rhain fod o gymorth i berchenogion dyfrdyllau sy'n bodoli'n barod er mwyn iddynt fedru diogelu eu tarddleoedd. Mae hefyd ar gyfer unrhyw un sy'n ystyried cael dyfrdwl wedi ei ddrilio. Mae'n dweud wrthy ch beth i edrych amdano, beth i'w ragnodi, a beth yw'ch cyfrifoldebau, yn ogystal â bod o gymorth i ddrilwyr gyflwyno prisiau realistig er mwyn gwneud y gwaith yn iawn ac er mwyn mabwysiadu y safonau uchel angenrheidiol. (Dangosir trawslun o ddyfrdwl tynnu dŵr nodweddiadol yn Diagram a).

### Pam fod angen y canllawiau?

Mae'n rhaid i ddyfrdyllau a ddefnyddir at ddibenion amaethyddol, masnachol, diwydiannol neu er mwyn cyflenwi dŵr i'r cyhoedd, gael caniatâd yr Asiantaeth i'w drilio a'u rhoi ar brawf a thrwydded er mwyn tynnu dŵr. Mae cyfrifoldeb ar berchenogion y tarddleoedd a'u contractwyr i sicrhau eu bod yn cael eu hadeiladu a'u diogelu'n gywir. Fel arfer caiff dyfrdyllau a ddriliwyd er mwyn dibenion cartref eu hesgusodi rhag gorfod cwrdd â'r gofynion rhain. Gan fod y tarddleoedd rhain yn aml yn cael eu defnyddio er mwyn cael hyd i ddŵr yfed mae'n bwysig darparu ymlaen llaw yn ystod y cyfnod cynllunio ac adeiladu er mwyn sicrhau nad yw'r tarddleoedd eu hunain yn cael eu difwyno, na chwaith bod y dŵr daear yn cael ei lygru yn gyffredinol.

Mae staff adnoddau dŵr yr Asiantaeth wedi gweld llawer o enghreifftiau o ddyfrdyllau cyflenwi dŵr preifat a adeiladwyd, a gwblhawyd neu a gynhaliwyd yn wael, a maent yn pryderu bod y perchenogion yn peryglu eu hunain, yn aml trwy anwybodaeth. Unwaith iddo gael ei ddrilio a'i gwblhau mae dyfrdwl yn aml "Allan o olwg, allan o feddwl" tan i bethau ddechrau mynd o chwith, e.e. mae'n cael ei ddifwyno, yn methu profion iechyd yr amgylchedd<sup>1</sup>, neu mae'r allbwn yn lleihau.

Ni fwriedir i'r canllawiau rhain fod yn argymhellol: nid oes gan yr Asiantaeth 'ragofynion safonol' ar gyfer drilio neu gwblhau dyfrdyllau cyflenwi dŵr<sup>2</sup>. Rhaid cwrdd ag amcanion cyffredinol, ond mae sut yn union y gwneir hyn yn fater, gan mwyaf, i'r cwsmer a'r contractwr benderfynu. Mae gan y ddau gyfrifoldebau cyfreithiol ac eraill a rhwymedigaethau cyfreithiol. Rhaid diogelu lles y cwsmer, tra bod y contractwr, fel arfer, yn cael ei ystyried fel 'yr arbenigwr' ar y pwnc, a disgwyliar iddo ddefnyddio

cynlluniau, defnyddiau a saemnaeth sy'n addas i'r lleoliad a'r peryglon.

### Beth sy'n cael ei gynnwys yn y canllawiau?

Mae'r canllawiau'n canolbwyntio ar yr agweddau rheini, sef lleoli dyfrdyllau, eu hadeiladu a chynllunio'r blaenwaith, sy'n berthnasol i warchodaeth y tarddle.

### Ystyriaethau eraill

Mae yna nifer o ffactorau eraill sy'n rhaid eu hystyried wrth gynllunio neu adeiladu dyfrdwl, sydd y tu hwnt i faes y canllawiau rhain. Mae'r rhain yn cynnwys:

- gofynion trwydded tynnu dŵr/ caniatâd i ymchwilio dŵr daear (Deddf Adnoddau Dŵr 1991);
- iechyd a diogelwch;
- diogelwch a rheoliadau trydanol peryglon o nwyon gwenwynig neu ffrwydrod;
- carthffosydd sy'n goll wng, cael gwared ar elfion o danciau carthion;
- cadw, trin a gollyngiadau damweiniol yng nghyswllt tanwydd a chemegau;
- presenoldeb gwasanaethau dan ddaear (nwy, trydan a.y.y.b.);



*Blaenwaith ar yr wyneb (ymarfer da) (yn dal heb gael ei goncridio yn wastad â'r llawr), ond wedi ei lleoli ger cemegau wedi eu storio (ymarfer gwael)*

Ceir rhestr o gyfeiriadau defnyddiol ar ddiwedd y ddogfe hon.

### Rhwymedigaethau Cyfreithiol

Mae'n dramgwydd troseddol i "achosi neu i ganiatáu gan wybod" i ddŵr daear gael ei lygru, gyda chosbau trymion (£20,000 o ddirwy fel uchafgost mewn llys ynadon, neu ddirwy ddiderfyn a/neu garchar os ceir yn euog ar Dditad). Felly, os yw perchenogion tarddleoedd yn caniatáu i ddŵr daear gael ei lygru trwy, er enghraifft, lygredd ar yr wyneb yn draenio i lawr i'w dyfrdwl, maent nid yn unig yn peryglu eu cyflenwad dŵr eu hunain, ond medrent hefyd gael eu herlyn gan Asiantaeth yr Amgylchedd, a bod yn gyfrifol am gael gwared ar y llygredd o'r dŵr daear. Yn yr un modd, os nad yw'r contractwr yn cynllunio neu'n adeiladu'r dyfrdwl yn y dull cywir, gan ystyried y peryglon, medrai yntau fod yn atebol.

# Water Supply Borehole Construction and Headworks

## GUIDE TO GOOD PRACTICE

This guidance has been prepared by the Environment Agency (the Agency) to raise awareness of both good and bad practice in the siting, construction and completion of water supply boreholes.

### Who is it aimed at?

It is intended to help owners of existing boreholes to protect their sources. It is also for anyone considering having a borehole drilled. It tells you what to look for, what to specify and what your responsibilities are, as well as helping drillers submit realistic prices for doing the job properly and to adopt the necessary high standards. (A cross section through a typical abstraction borehole is shown in Diagram a).

### Why is it needed?

Boreholes used for agricultural, commercial, industrial or public water supply purposes require the consent of the Agency to drill and test them and a licence to abstract. It is the responsibility of source owners and their contractors to ensure that they are properly constructed and protected. Boreholes drilled for domestic purposes are normally exempt from these requirements. Since these sources are often used for potable purposes it is important that the right precautions are taken at the planning and construction stage, to prevent contamination of the sources themselves and pollution to the groundwater in general.

Agency water resources staff have seen many examples of badly constructed, completed or maintained private water supply boreholes, and are concerned at the risks to which source owners are subjecting themselves, often out of ignorance. Once drilled and completed a borehole is often "out of sight and out of mind" – until things go wrong, e.g. becomes polluted, fails environmental health checks<sup>1</sup>, or the output falls.

These guidelines are not intended to be prescriptive; the Agency does not have a "standard specification" for drilling or completing water supply boreholes<sup>2</sup>. Common objectives must be met, but precisely how they are achieved is mainly a matter for the client and contractor. Both have legal and other responsibilities and legal liabilities. The client's interests must be protected, whilst the contractor is usually looked on as 'the expert' in these matters, and is expected to use designs, materials and workmanship appropriate to the setting and risks.

See footnotes at end of document

### What does it cover?

The guidelines focus on those aspects of borehole siting, construction and headworks design relevant to source protection.

### Other considerations

There are a number of other factors that need to be considered when planning or constructing a borehole, which are beyond the scope of this guidance. They include :

- abstraction licence/ groundwater investigation consent requirements (Water Resources Act, 1991);
- health and safety;
- electrical safety and regulations;
- dangers from toxic or explosive gases;
- leaking sewers, effluent disposal from septic tanks;
- storage, handling and accidental spillages of fuels and chemicals;
- the presence of buried services (gas, electric etc).



*Above ground headworks (good practice) (still to be concreted at ground level), but sited close to stored chemical (bad practice)*

A list of useful references can be found at the back of this document.

### Legal liabilities

It is a criminal offence to "cause or knowingly permit" groundwater to become polluted, with heavy penalties (£20,000 maximum fine in a magistrates court, or an unlimited fine and/ or imprisonment on indictment). Therefore, if source owners allow pollution of groundwater to occur, for example by surface contamination draining down their borehole, they not only jeopardise their own water supply, but they could also be prosecuted by the Environment Agency, and be responsible for cleaning up the groundwater. Similarly, if the contractor does not design or construct the borehole properly, taking account of the risks, they too could be liable.



*Cadw cemegau a thanwydd ger ac ar lethr i fyny o ddyfrdwl a gafodd ei gwblhau dan ddaear heb ffos yn y twll archwilio...*

Unwaith y llygrwyd ef mae dŵr daear bob amser yn ddrud ac yn aml yn amhosibl i'w lanhau. Athroniaeth Asiantaeth yr Amgylchedd yw **"gwell rhwystr o'r clwy na'i wella"**.

## Lleoli dyfrdyllau

Mae dogfen yr Asiantaeth "Polisi ac Ymarfer ar gyfer Gwarchod Dŵr Daear" yn rhagnodi parth mewnol er mwyn gwarchod y tarddle (parth 1) o 50m (neu cyfnod o deithio o 50 diwrnod<sup>3</sup>, pa un bynnag sydd fwyaf) o gwmpas dyfrdyllau neu ffynhonnau a ddefnyddir at ddŵr yfed, a byddem, fel arfer, yn gwrthwynebu unrhyw weithgareddau o fewn y parth hwn a fedrai fygwth y tarddleoedd rheini. Mae "Cöd Dŵr" (1998) y Weinyddiaeth Amaethyddiaeth, Pysgodfeydd a Bwyd yn gwahardd llawer o weithgareddau sy'n ymwneud â thrin a chael gwared ar elifion fferm yn agos at gyflenwadau dŵr yfed.

Oherwydd hyn, mae'n bwysig, wrth adeiladu tarddleoedd newydd, i gofio am y cyfyngiadau rhain a rhoi yr un egwyddorion rhagofalus ar waith ag a grybwyllwyd uchod. O'r cychwyn cyntaf, cyngorior y cwsmer a'r contractwr i drafod lleoliad y dyfrdwl.

Dylai fod ar lethr i fyny ac yn bell oddi wrth unrhyw ffynhonnell ddichonol o lygredd, gan gynnwys:

- tanciau tanwydd, cemegau, slyri neu silwair neu ardaloedd lle mae'r sylweddau rhain yn cael eu cadw neu eu trin;
- tanciau carthion a cwteri cael gwared ar elifion<sup>4</sup>
- carthffosydd neu bibau tanwydd dan y ddaear;
- tir sy'n draenio'n wael a thir lle ceir draenio dyfroedd ffo llygredig.

## Cwblhau'r blaenwaith

Daeth yn arferiad i'r rhan fwyaf o ddyfrdyllau cartref neu fferm, yn ogystal â llawer ar safleoedd diwydiannol, gael eu cwblhau dan y ddaear, mewn tyllau archwiliad. Dyma'r dull sy'n lleiaf ymwthiol yn weladwy a gall fod yn angenrheidiol ble mae tir yn brin iawn. Fodd bynnag, o safbwynt gwarchod tarddleoedd, mae hyn yn eu gwneud yn hawdd iawn i'w hesgeuluso ac i'w llygru gan sylweddau llygredig o'r wyneb yn dilyn llwybr uniongyrchol i lawr i'r dyfrdwl.

*Ymarfer gwael – dim growt y tu ôl i'r casin, dim slabyn gwaelod wedi ei selio. Dim ffos.*



*Dim growt y tu ôl i'r casin*

## Oherwydd hyn, mae'r Asiantaeth yn argymhell yn gryf y dylid cwblhau blaenwaith y dyfrdwl ar yr wyneb

(gweler esiampl Diagram **b**), yn enwedig mewn sefyllfaoedd peryglus iawn fel ffermydd a safleoedd diwydiannol. Ble nad oes dewis arall ond i gwblhau'r blaenwaith dan y ddaear, mae safonau uchel dros ben ogyllunio'r blaenwaith, adeiladu a chynnal a gwarchod cyfredol yn hanfodol (gweler esiampl Diagram **c**).



*...yn arwain at sylweddau draeniad llygredig (olewau a cemegau) yn boddi'r siambr ac yn llygru'r dyfrdwl.*

## Profion Pwmpio

Fel arfer, bydd yr Asiantaeth yn penodi cyfnod o bwmpio prawf ar gyfradd gyson ar gyfer tarddleoedd sydd arnynt angen caniatâd. Fodd bynnag, hyd yn oed mewn tarddleoedd sy'n esgusodedig rhag gorfod cael trwydded rydym yn argymhell gwneud prawf pwmpio byr (a elwir yn aml yn "weithbrawf") a bod perchenogion y tarddle yn cymryd sylw o'r canlyniadau. Dylid cymryd samplau o ansawdd y dŵr ar ddiwedd y prawf, er mwyn darganfod os yw'r tarddle'n llygredig ac os yw'r dŵr yn ddiogel i'w ddefnyddio at y pwrpas arfaethedig. Mae'r pwnc olaf hwn yn rhan o gyfrifoldeb adran leol lechyd yr Amgylchedd (gweler troednodyn 1). Yn ogystal â samplu ansawdd, mae'n bwysig bod y gyfradd bwmpio a lefelau'r dŵr yn cael eu mesur yn fanwl gywir cyn, yn ystod ac ar ôl y cyfnod pwmpio. Meddir defnyddio'r wybodaeth er mwyn dewis offer pwmpio parhaol sy'n addas. Mae hefyd yn ddull o fesur perfformiad y dyfrdwl ar adeg ei ddrilio, a gall fod yn gofnod defnyddiol er mwyn dangos unrhyw ddirywiad yn y dyfodol ym mherfformiad y dyfrdwl neu'r pwmp, neu or-bwmpio o'r ddyfrhaen a dapiwyd gan y dyfrdwl. Argymhellir bod perchenogion tarddleoedd yn cael cofnodion o lefelau dŵr y dyfrdwl yn ystod bywyd gweithredol y dyfrdwl. Gall hyn fod yn amod o rai trwyddedau tynnu dŵr a roddir gan yr Asiantaeth.

## Cofnodion Dyfrdyllau

Dylai perchenogion tarddleoedd fynnu copi o gofnodlyfr y driliwr oddi wrth eu contractwyr tra bod y gwaith o adeiladu ac o wneud profion yn mynd yn ei flaen, sy'n dangos manylion yr adeiladwaith a'r haenau a aethpwyd drwyddynt, yn ogystal â chanlyniadau y profion pwmpio.

Er nad oes gorfodaeth i wneud hyn ar berchenogion tarddleoedd sy'n esgusodedig rhag gorfod cael trwydded, argymhellir yn gryf bod manylion y dyfrdwl, gan gynnwys ei leoliad a chofnodlyfr y driliwr, yn cael eu hanfon i swyddfa leol Asiantaeth yr Amgylchedd<sup>5</sup>. Mae hyn yn caniatáu i staff yr Asiantaeth warchod y tarddle rhag gweithgareddau eraill a fedrent gael effaith dichonol ar y tarddle, er enghraifft, os arfaethir chwareli, safleoedd tirlenwi, arllwysyadau o danciau carthion neu ddyfrdyllau newydd.

**Os nad ydym yn gwybod amdano, fedrwn ni mo'i warchod.**



*Storage of chemicals and fuels close to and up-slope of a borehole which is completed below ground, with no drain in manhole...*

Once polluted groundwater is always expensive, and often impossible, to clean up. The Agency's philosophy is that "prevention is better than cure".

## Borehole location

The Agency's "Policy and Practice for the Protection of Groundwater" recognises an inner source protection zone (zone 1) of 50 m (or a 50-day travel time<sup>3</sup>, whichever is greater) around boreholes or wells used for potable purposes, within which we would normally object to any activities that could threaten those sources of supply. The MAFF "Water Code" (1998) prohibits many farm effluent handling or disposal activities close to potable water supplies.

When constructing new sources, therefore, it is important to bear these constraints in mind and apply the same precautionary principles as above. From the outset the client and contractor are advised to discuss the siting of the borehole.

It should be up-slope and remote from any potential source of pollution, including:

- fuel, chemical, slurry or silage tanks or areas where these substances are stored or handled;
- septic tanks and effluent disposal drains;<sup>4</sup>
- sewers or below-ground fuel pipes;
- poorly drained areas and areas subject to contaminated drainage run off.

## Headworks completion

It has become custom and practice for most domestic and farm boreholes, as well as many on industrial sites, to be completed below ground, in manholes. This is the least visually intrusive and may be necessary where land availability is severely restricted.

However, from a source protection point of view this makes them highly vulnerable to neglect and to pollution resulting from contaminated surface drainage tracking directly down the borehole.

*Bad practice - no grout behind casing, no sealed base slab. No drain.*



*No grout behind casing*

The Agency therefore strongly recommends that borehole headworks are completed above ground level (see example

Diagram b), particularly in high-risk situations such as farms and industrial sites. Where there is no alternative to a below-ground completion, exceptionally high standards of headworks design, construction and ongoing maintenance and protection are essential (see example Diagram c).



*...resulting in contaminated drainage (oils and chemicals) flooding the chamber and polluting the borehole*

## Test pumping

The Agency will normally specify a period of constant rate test pumping for sources that require consent. However, even in the case of licence-exempt sources we recommend that a short pumping test be carried out (often referred to as a 'proving test'), and that source owners take an interest in the results. Water quality samples should be taken at the end of the test, to determine whether the source is contaminated and whether the water is fit for the intended use. The latter issue falls within the remit of the local Environmental Health department (see footnote 1). In addition to quality sampling, it is important that the pumping rates and water levels are measured accurately before, during and after the pumping period.

The information obtained can be used to select appropriate permanent pumping equipment. It also is a measure of the borehole performance at the time of drilling, and can be a useful reference to indicate future deterioration in the borehole or pump performance, or overpumping of the aquifer unit tapped by the borehole. Source owners are advised to keep records of borehole water levels during the operational life of the borehole. This may be a condition of some abstraction licences granted by the Agency.

## Borehole records

Source owners should obtain a copy of the drillers log, showing construction details and strata penetrated, as well as the pumping test results, from their contractor at the time of construction and testing.

Although in the case of licence-exempt boreholes, source owners are not obliged to, it is strongly recommended that details of the borehole, including the location and drillers log, are sent to the local Environment Agency office<sup>5</sup>. This then allows Agency staff to protect the source from other activities that could potentially affect the source, for example proposed quarries, landfills, septic tank discharges or new boreholes.

**If we don't know about it we can't protect it.**

## Ar gipolwg

	Ymarfer Da	Ymarfer Gwael	Amcanion
<b>Lleoliad</b>	Yn bell ac ar lethr i fyny o unrhyw darddleuedd llygredd.	Ar dir isel lle gall sylweddau llygredig ddraenio a chasglu. Ger tarddleuedd llygredd e.e. – tanwydd/tanciau cemegau/storfeydd/ardaloedd trin. (Gweler esiampl e).	I osgoi lleoli ger tarddleuedd dichonol o lygredd neu ble gall sylweddau o'r wyneb ddraenio i'r dyfrdwl.
<b>Casin parhaol: math</b>	Y Safon Brydeinig, safon y diwydiant olew (API) neu gasin safonol ffynnon ddŵr <sup>6</sup> .	Pibellau carthion neu ddraeniad.	I ynysu tir tenau, ansefydlog neu lygredig;
<b>defnydd</b>	Dur/ <sup>7</sup> plastig o safon ffynnon ddŵr.		I selio a rhwystro dŵr daear bas, llygredig a dŵr o'r wyneb rhag dilyn llwybr i lawr drwy'r dyfrdwl i'r lefel trwythiad;
<b>cymaliad</b>	Wedi ei asio, ei sgriwio ac yn socedog.	Ffit wthio.	
<b>diamedr</b>	Yn ddigon o faint i ganiatáu gosod tiwb(iau) dipio yn ogystal â cheblau ynni a phibell ymgodol. Yn ddigon bach i ddarparu anwlws o 50mm o leiaf er mwyn caniatáu growtio effeithiol dan bwysedd <sup>8</sup> .	Rhy fach i ganiatáu gosod y tiwb(iau) dipio.  Rhy fawr i ganiatáu growtio effeithiol dan bwysedd yn yr anwlws rhwng y casin a wal y dyfrdwl.	I rwystro gwahanol ddyfrhaenau rhag cydgyssylltu;  I rwystro arllwysiadau artesiaidd direolaeth <sup>11</sup> .
<b>dyfnder</b>	Yn arferol o leiaf 15m. Pan fo'r dyfrdyllau yn rhai agored mewn craig, dylid gosod y casin o leiaf 3m i fewn i graig solet. Efallai bydd angen gosod yn ddyfnach er mwyn ynysu tir ansefydlog neu lygredig neu ddyfrhaenau gwahanol oddi wrth ei gilydd <sup>9</sup> .	Sêl annigonol. Graean solet.	
<b>cantelau/selïau</b>	Casin slaes sgwâr, cantel a asiwyd. Cap cantellog a bolltlog i'r dyfrdwl, gyda sêl neopren <sup>10</sup> .	Dim sêl/plât cantel. Casin slaes fras. Torrwyd ymaith yn rhy agos at waelod y siambr.	
<b>Growtio</b>	Growtio dan bwysedd o waelod y casin parhaol i fyny i'r wyneb.  Dylid caniatáu i'r growt galedu am o leiaf 24 awr cyn drilio'n ddyfnach. Anwlws o 38mm o leiaf.	Growt wedi ei arllwys o'r wyneb. Casin wedi ei guro i fewn yn unig heb ei growtio. Ail-ddechrau drilio cyn i'r growt galedu <sup>12</sup> .	I selio a rhwystro dŵr daear bas, llygredig a dŵr o'r wyneb rhag dilyn llwybr i lawr drwy'r dyfrdwl i'r lefel trwythiad.
<b>Cwblhau</b>	Ar wyneb y tir, naill ai mewn tŷ pypiau neu mewn ardal warchoddedig heb drafnidiaeth.	Dan y ddaear, a heb ei selio.	

Gweler y troednodiadau ar ddiwedd y ddogfen

## At a glance

	Good Practice	Bad Practice	Objectives
<b>Location</b>	Remote from and up-slope of any pollution sources.	At low points where contaminated drainage can collect. Near sources of pollution e.g. – fuel/chemical tanks/storage/handling areas. (See example Diagram e).	To avoid siting near potential sources of pollution or where surface drainage can run into the borehole.
<b>Permanent Casing:</b> <i>type</i>	British Standard, oil industry (API) standard or waterwell standard casing <sup>6</sup> .	Drainage or sewer pipes.	To seal off shallow unstable or contaminated ground;
<i>material</i>	Steel/ <sup>7</sup> waterwell grade plastic.		To seal off and prevent tracking of contaminated shallow groundwater and surface water via the borehole to the water table;
<i>jointing</i>	Welded, screwed and socketed.	Push-fit.	To prevent interconnection of different aquifer layers;
<i>diameter</i>	Large enough to allow installation of dip tube(s) as well as rising main and power cable. Small enough to provide an annulus of at least 50mm to allow effective pressure grouting <sup>8</sup> .	Too small to allow installation of dip tube(s).  Too large to allow effective pressure grouting of annulus between casing and borehole wall.	To prevent uncontrolled artesian discharges <sup>11</sup> .
<i>depth</i>	Normally at least 15m. In the case of open boreholes in rock, casing should be inserted at least 3m into solid rock. A greater depth may be necessary to seal off unstable or contaminated ground or different aquifer units <sup>9</sup> .	Inadequate seal. Solid gravel.	
<i>flanges/seals</i>	Square-cut casing, welded flange. Flanged and bolted borehole cap, with neoprene seal <sup>10</sup> .	No seal/flange plate. Rough cut casing. Cut off too close to base of chamber.	
<b>Grouting</b>	Pressure grouting from base of permanent casing up to surface.  Allow a minimum of 24 hours for grout to set before drilling deeper. Minimum annulus 38mm.	Grout poured from surface. Casing just driven not grouted.  Drilling recommenced before grout has set and hardened <sup>12</sup> .	To seal off and prevent tracking of contaminated shallow groundwater and surface water via the borehole to the water table.
<b>Completion</b>	Above ground, either in a pump house or protected area not subject to traffic.	Below ground, and not sealed.	

See footnotes at end of document

## Ar gipolwg

	Ymarfer Da	Ymarfer Gwael	Amcanion
<b>Siambur y twll archwiliad<sup>13</sup> gwaelod</b>	Concrid, 150 mm o drwch.	Concrid <100m neu dir naturiol.	I rwystro dŵr neu sylweddau llygredig sy'n draenio rhag crynhoi yn siambur y twll
<b>ochrau</b>	Adrannau concrid cyn-gastiedig, briciau peirianyddol neufriciau/ waith blociau gwrth-ddŵr wedi eu rendro (wedi eu hasio i'r gwaelod).	Briciau neu waith blociau heb fod wedi eu trin i ddal dŵr.	archwiliad, trwy leiafu mewnllif dŵr a darparu draeniad allan o siambur y twll archwiliad.
<b>caead</b>	Yn medru cario pwysau yn ôl gofynion y drafnidiaeth. Ffrâm y caead wedi ei hansiio a'i asio i'r ochrau. Sêl gwrth-ddŵr.	Caead ysgafn (a fedrai gael ei niweidio gan drafnidiaeth). Ffrâm heb ei selio i'r ochrau. (Gweler Diagram <b>d</b> )	
<b>cwter</b>	Diamedr o leiaf 25 mm ID gyda sgrîn fermin, yn arwain at agorfa ar yr wyneb neu suddfan ddŵr effeithiol <sup>14</sup> .	Dim cwter, na suddfan ddŵr, cwter tagedig neu dwll archwiliad wedi ei adeiladu islaw'r lefel trwythaid neu mewn tir dyfrlawn neu ar dir sy'n draenio'n wael.	
<b>ôl-lenwi'r siambur</b>	Defnydd o hydreiddedd isel fel clai.	Defnydd o hydreiddedd uchel mewn tir dyfrlawn neu ar dir sy'n draenio'n wael.	
<b>Tiwbiau Dipio<sup>15</sup></b>	Diamedr o leiaf 25mm ID. Y 3m gwaelod wedi ei ridyllu â thyllau bob 100mm. Gwaelod â phlwg / bar er mwyn rhwystro'r llestr mesur rhag rhedeg allan o'r tiwb dipio. Dylai'r gwaelod fod o leiaf 2 fedr yn is na lefel mewnllif y pwmp neu'n ddigon o dan y lefel trwythiad er mwyn medru ymdopi â newidiadau yn y dyfodol yn lefel y dŵr (pwmpio a naturiol). Plwg y gellir ei dynnu ar ben y tiwb.	Ni ddarparwyd rhai. O ddyfnder annigonol. Â gwaelod agored (sy'n caniatáu i'r llestr mesur redeg allan o'r gwaelod). Heb eu rhidyllu.	Mynediad diogel i ganiatáu mesur lefel y dŵr mewn dull dibynadwy.  Rhwystro tasgu/diferiadau lefel uchel rhag rhoi darlenniadau ffug.  Wedi eu selio er mwyn rhwystro'r dyfrdwl rhag cael ei lygru, arllwysyadau artesiadd neu ollyngiadau nwy fel y bo'n addas.
<b>Awyrellu</b>	Naill ai system wedi ei selio'n llwyr, er enghraifft ar gyfer dyfrdyllau artesiadd, neu siambur y twll archwiliad/adeilad a chronfeydd storio wedi eu hawyrellu yn unol â chanllawiau o'r Awdurdod Gweithredol Iechyd a Diogelwch <sup>16</sup> . Cwblhau'r dyfrdwl ar yr wyneb mewn awyrgylch agored.	Lleoliad mewn adeilad neu siambur a fyddai'n creu lle cyfyng.  Pethau a fedrai achosi tanio o offer trydanol (gan gynnwys offer swits a goleuadau) yn agos at y dyfrdwl neu mewn lle cyfyng (ble mae yna berygl o nwy yn cronni).	I osgoi'r perygl o nwyon gwenwynig neu ffrwydrod yn cronni yn y cronfeydd storio, siambur y twll archwiliad neu'r adeiladau <sup>17</sup> .
<b>Llif-fesurydd</b>	Gosodwyd yn unol â chanllawiau ymarfer da yr Asiantaeth ar fesur.	Wedi ei osod ar rediadau byrion o bibellau, yn agos at blygiadau a falfiau.	Ble mynnir hyn gan yr Asiantaeth, dylai'r llif-fesurydd gael ei galibradu, ei osod a'i gynnal er mwyn sicrhau mesuriadau cywir o faint o ddŵr sy'n cael ei dynnu.

## At a glance

	Good Practice	Bad Practice	Objectives
<b>Manhole Chamber:</b> <sup>13</sup> <i>base</i>	Concrete, 150mm thick.	Concrete <100mm or natural ground.	To prevent water or contaminated drainage accumulation in the manhole chamber, by minimising water entry and providing drainage out of the manhole chamber.
<i>sides</i>	Precast concrete sections, engineering brick or waterproof rendered brick/blockwork (bonded to base).	Brick or blockwork, not waterproofed.	
<i>cover</i>	Load bearing to suit traffic. Cover frame haunched and bonded to sides. Water-tight seal.	Lightweight cover (potentially damaged by traffic). Frame not sealed to sides. (See Diagram <b>d</b> )	
<i>drain</i>	25mm ID min. diam with vermin screen, leading to surface outlet or effective soakaway <sup>14</sup> .	No drain, no soakaway, blocked drain or manhole constructed below water table or in waterlogged or poorly drained ground.	
<i>chamber backfill</i>	Low permeability material such as clay.	High porosity material in waterlogged or poorly drained ground.	
<b>Dip Tubes</b> <sup>15</sup>	25mm ID min. diam. Bottom 3m perforated at 100mm centres. Base with plug/bar to prevent dipper running out of dip tube. Bottom at least 2m below the pump intake level or sufficiently below water table to accommodate future changes in water level (pumping and natural). Removable plug in top.	None provided. Not deep enough. Open ended (allows dipper to run out of bottom). Not perforated.	Safe access to allow reliable water level measurement.  Prevent splashing/high level seepages giving spurious readings.  Sealed to prevent contamination of borehole, artesian discharge or gas escape as appropriate.
<b>Venting</b>	Either totally sealed system for artesian boreholes for example or manhole chamber/building and storage vessels vented according to guidance from HSE <sup>16</sup> . Borehole completed above ground in an open atmosphere.	Siting in a building or a chamber which would constitute a confined space.  Potential sources of ignition from electrical equipment (including switchgear and lights) close to borehole or in a confined space (where there is a risk of gas accumulation).	To avoid risk of accumulation of toxic or explosive gases in borehole chamber storage vessels or buildings <sup>17</sup> .
<b>Flowmeter</b>	Installed in accordance with Agency good practice guidance on metering.	Fitted on short pipe runs, close to bends and valves.	Where required by the Agency a meter should be calibrated, installed and maintained to ensure accurate measurement of abstraction quantities.

See footnotes at end of document



# Trawslun sgematig cyffredinol o ddyfrdwl ar gyfer tynnu dŵr

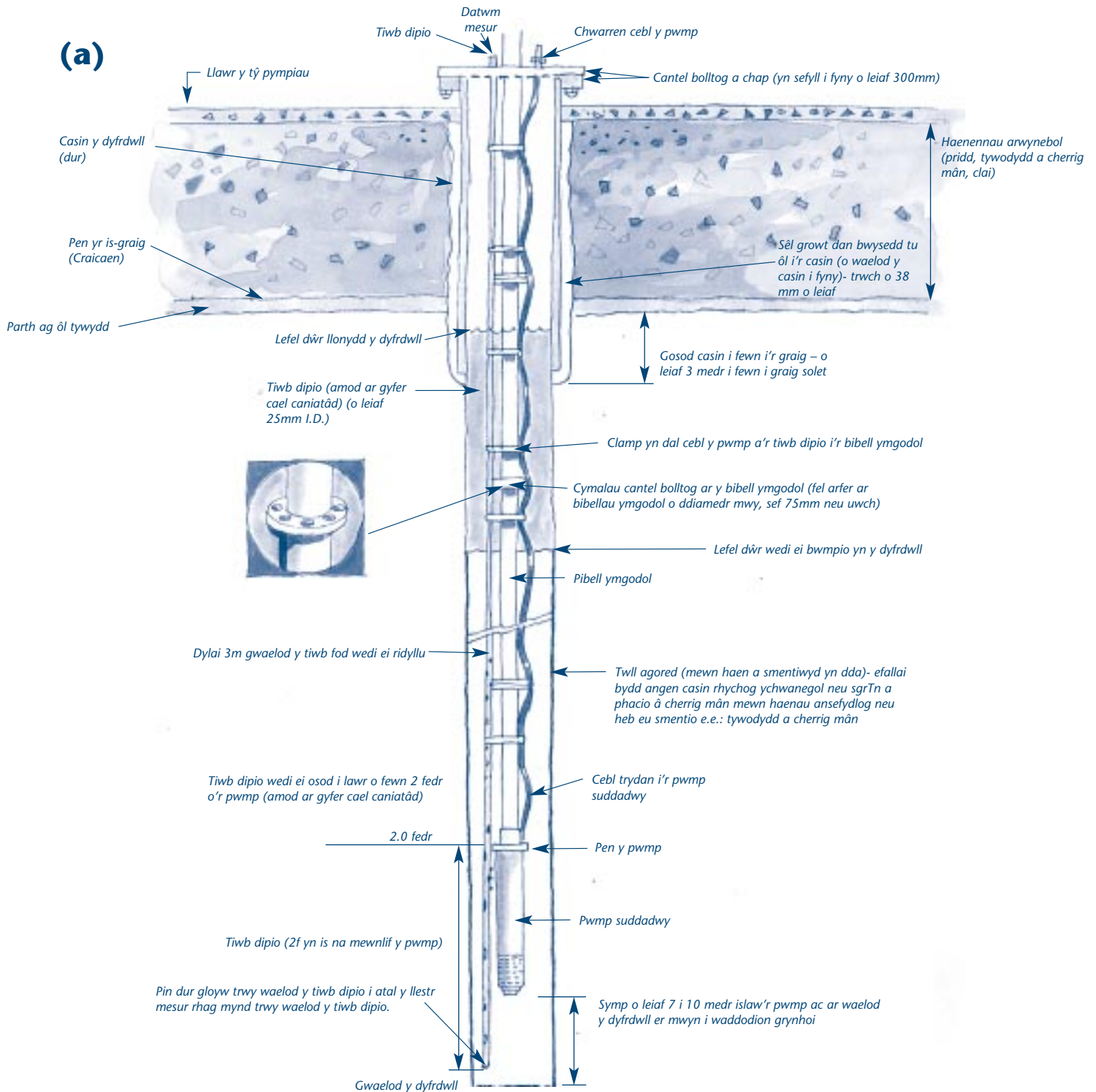

Dyfrdwl fferm. Yn arddangos ymarfer da sef cwblhau gwaith pen y twll ar yr wyneb, ar lethr i fyny o darddleuedd dichonol o lygredd.



# General schematic section of an abstraction borehole

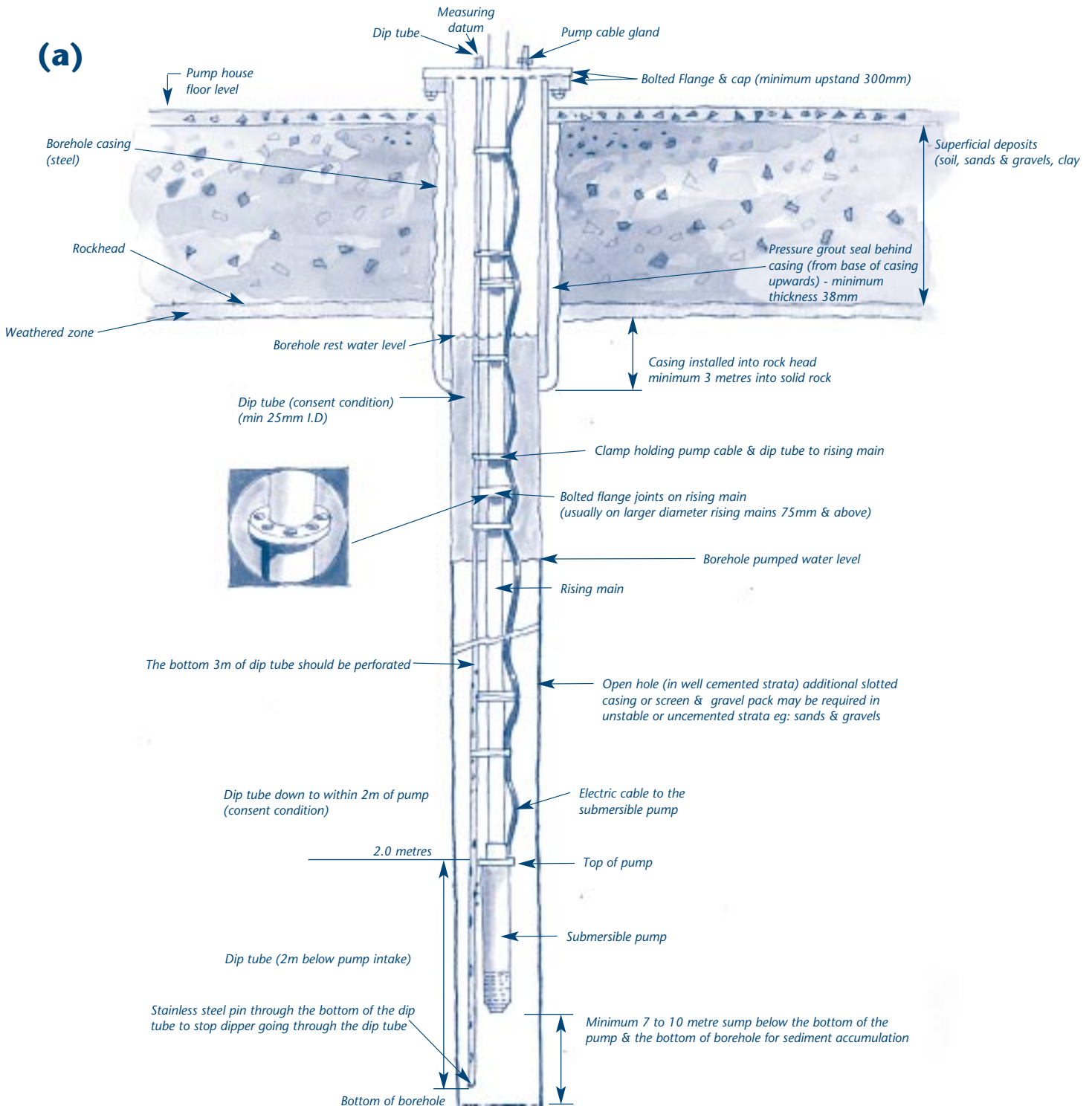

*Farm borehole. Good practice above ground headworks completion, upslope of potential sources of pollution.*



# ENGHREIFFTIAU O YMARFER DA

Cyhoeddir y diagram hwn fel canllaw yn unig  
**Cwblhau ar wyneb y tir**

YMARFER DA A ARGYMHELLIR

## Allwedd i ffigur (b)

- A** - Ffrâm sy'n cynnal caead y twll archwiliad wedi ei blannu a'i hansio mewn priddgalch dosbarth un.
- B** - Caead y twll archwilio
- C** - Walliau siambr ar bedair ochr o friciau peiranyddol dosbarth "B", 210mm o drwch
- D** - Pibell gyflenwi
- E** - Dylid selio'r bibell gyflenwi ar y tu allan wrth iddi fynd drwy'r siambr
- F** - (Noder; dylid gosod y llif-fesurydd yn unol â chanllawiau ymarfer da yr Asiantaeth)
- G** - Cwter siambr o leiaf I.D  $1\frac{1}{2} \times 37\text{mm}$
- H** - Cantel bolltog a chap
- I** - Tiwb dipio a chap

- J** - Cebl a chwarren y pwmp
- K** - Gased a seliwyd â neopren rhwng y cantel a'r cap
- L** - Amddiffyn y bibell gyflenwi rhag rhow fel y bo'n addas
- M** - Caead gwifwrwe fermin
- N** - Lleiafswm pellter rhwng pen y cantel a'r concrid 300mm
- O** - Casin y dyfrdwill (dur)
- P** - Lefel llawr y siambr yn disgyn tua'r gwter
- Q** - Tiwb dipio
- R** - Pibell ymgodol
- S** - Cebl y pwmp
- T** - Growt (Trwch o 38 mm o leiaf)
- U** - Sylfaen concrid 150mm o drwch o leiaf

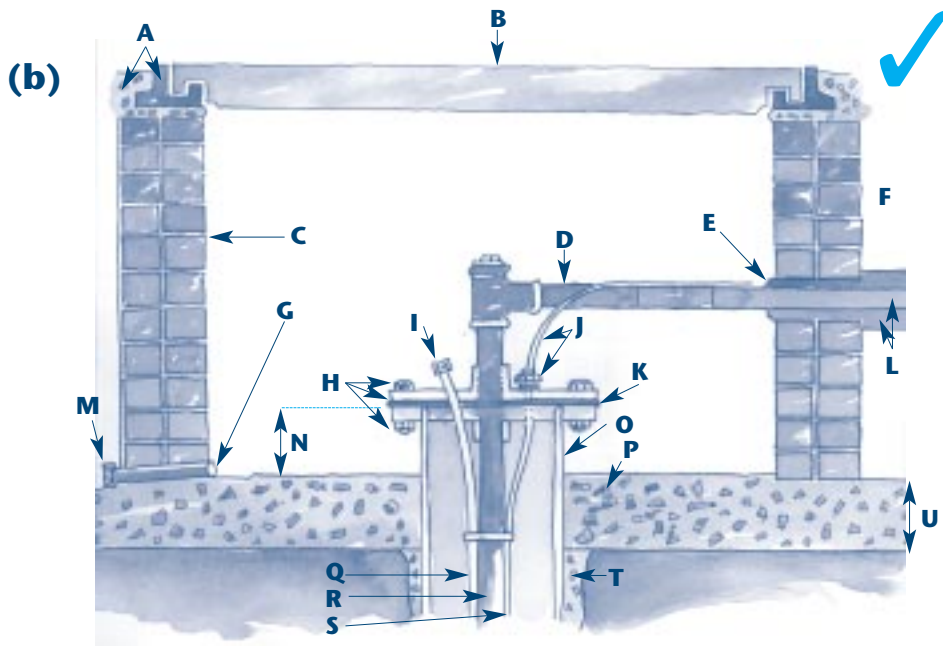

## EXAMPLES OF GOOD PRACTICE

This diagram is issued as guidance only

### Above ground completion

RECOMMENDED GOOD PRACTICE

#### Key to figure (b)

- A** - M/H cover support frame embedded & haunched in class 1 mortar.
- B** - M/H cover
- C** - 210mm thick class "B" engineering brick chamber walls to 4 sides
- D** - Delivery pipe
- E** - Delivery pipe to be sealed around the outside as it passes through chamber wall
- F** - (Note: meter to be installed in accordance with Agency's good practice guidelines.)
- G** - Chamber drain min ID  $1\frac{1}{2} \times 37\text{mm}$
- H** - Bolted flange and cap
- I** - Dip tube & cap

- J** - Pump cable & gland
- K** - Neoprene sealing gasket between flange & cap
- L** - Delivery pipe protected against frost as appropriate
- M** - Vermin gauze cover
- N** - Min distance between top of flange & concrete 300mm
- O** - Borehole casing (steel)
- P** - Chamber floor level falling towards drain
- Q** - Dip tube
- R** - Riser main
- S** - Pump cable
- T** - Grout (minimum thickness 38 mm)
- U** - Concrete base min 150mm thick

# ENGHREIFFTIAU O YMARFER DA

Cyhoeddir y diagram hwn fel canllaw yn unig

## Cwblhau dan ddaear YMARFER DA Cymeradwy

(Dim ond ble mae cwblhau ar yr wyneb yn anymarferol)

### Allwedd i ffigur (C)

- A** - Ffrâm sy'n cynnal caead y twll archwiliad wedi ei blannu a'i hansio mewn pridd galch dosbarth un.
- B** - Caead y twll archwiliad
- C** - Dylai caead y twll archwiliad fod o ansawdd trwm er mwyn cario trafnidiaeth berthnasol
- D** - Lefel y ddaear yn disgyn i ffwrdd o gaead y siambr
- E** - Noder: Awyrellu ar gyfer methan neu system wedi ei selio'n llwyr ( yn ôl canllawiau'r Awdurdod Gweithredol Iechyd a Diogelwch)
- F** - Dylai hansio fod yn is na phen y gwaith briciau er mwyn sicrhau sêl dwrglos
- G** - Walliau siambr ar bedair ochr o friciau peirianyddol dosbarth "B", 210mm o drwch
- H** - Pibell gyflenwi
- I** - Dylid selio'r bibell gyflenwi ar y tu allan wrth iddi fynd drwy'r siambr
- J** - Cebel a chwarren y pwmp
- K** - Gasged a seliwyd â neopren rhwng y cantel a'r cap

- L** - Cantel wedi ei asio i'r casin
- M** - Casin y dyfrdwill (dur)
- N** - Lefel llawr y siambr yn disgyn tua'r gwter
- O** - Ôl-lenwi â chlai cywasgedig ar bedair ochr y siambr
- P** - Sylfaen concrid 150mm o drwch o leiaf
- Q** - Tiwb dipio
- R** - Pibell ymgodol
- S** - Cebel y pwmp
- T** - Growt (Trwch o 38 mm o leiaf)
- U** - Noder: Dylai manylion y suddfan ddŵr ystyried cyflwr y tir h.y. hydreiddedd neu lefel trwythiad uchel
- V** - Cwter siambr o leiaf ID 37mm
- W** - Tiwb dipio a chap
- X** - Cantel bolltlog a chap
- Y** - Lleiafswm pellter rhwng pen y cantel a'r concrid 300mm

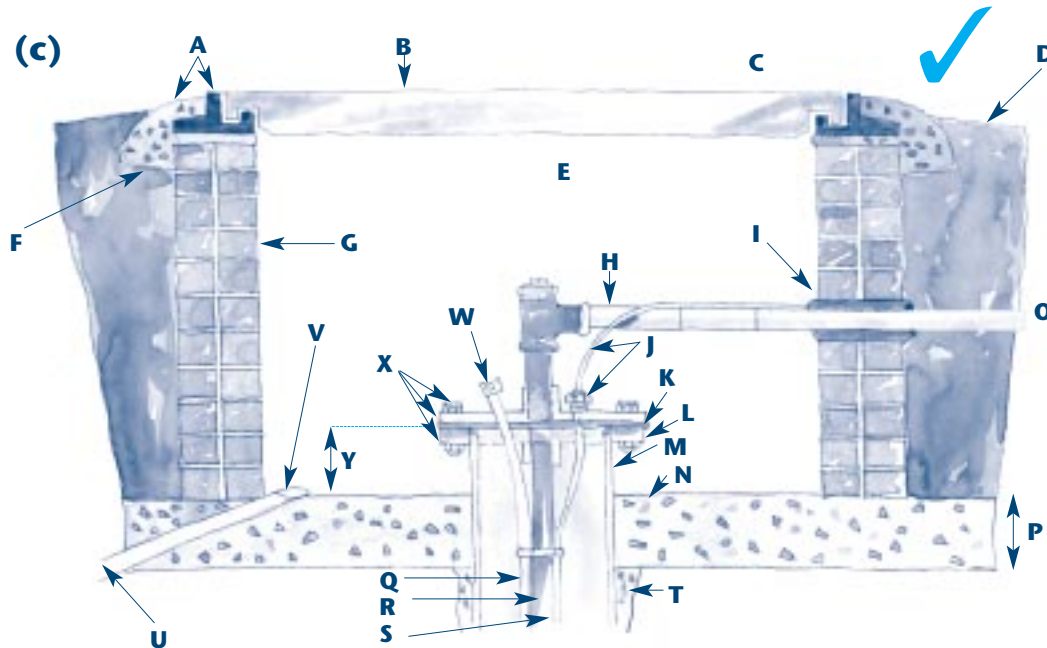

## EXAMPLES OF GOOD PRACTICE

This diagram is issued as guidance only

### Below ground completion Acceptable GOOD PRACTICE

(Only where an above ground completion is impractical)

#### Key to figure (C)

- A** - M/H cover support frame bedded & haunched in class 1 mortar.
- B** - M/H cover
- C** - The manhole cover should be of suitable heavy duty as to carry relevant traffic
- D** - Fall of GL away from chamber cover
- E** - Note: Venting for methane or totally sealed system (in accordance with H.S.E guide lines)
- F** - Haunching should be below top of brickwork to ensure water tight seal
- G** - 210mm thick class "B" engineering brick chamber walls to 4 sides
- H** - Delivery pipe
- I** - Delivery pipe to be sealed around the outside as it passes through chamber wall
- J** - Pump cable & gland
- K** - Neoprene sealing gasket between flange & cap
- L** - Flange welded to casing

- M** - Borehole casing (steel)
- N** - Chamber floor level falling towards drain
- O** - Compacted clay back fill to all 4 sides of chamber
- P** - Concrete base min 150mm thick
- Q** - Dip tube
- R** - Rising main
- S** - Pump cable
- T** - Grout (minimum thickness 38 mm)
- U** - Note: Soakaway detail needs to take account of ground conditions ie permeability or a high water table
- V** - Chamber drain min ID 37mm
- W** - Dip tube & cap
- X** - Bolted flange and cap
- Y** - Min distance between top of flange & concrete 300mm

## Canllawiau Defnyddiol Eraill

Mae canllawiau a rheoliadau perthnasol eraill yn cynnwys:

### Cyhoeddiadau Asiantaeth yr Amgylchedd

- “Polisi ac Ymarfer ar gyfer Gwarchod Dŵr Daear” (1998). Mae hwn yn datgan dull yr Asiantaeth o fynd ati i reoli a gwarchod dŵr daear.
- Canllawiau Atal Llygredd, sy’n rhoi cyngor ar rai gweithgareddau llygrol dichonol:
  - PPG 2** - Tanciau storio olew ar wyneb y ddaear
  - PPG 4** - Cael gwared ar garthion ble nad oes draeniad pibell ar gael
  - PPG 8** - Cadw ar chael gwared yn ddiogel ar olewau tanwydd a ddefnyddiwyd
  - PPG 9** - Atal llygru Dyfroedd Wedi’u Rheoli gan blaeiddiaid
  - PPG 12** - Atal llygru Dyfroedd Wedi’u Rheoli gan hylif trochi defaid
  - PPG 17** - Llaethdai a gweithgareddau trin llaeth eraill
- “Chwilio am ddŵr daear”, sy’n egluro gofynion yr Asiantaeth ar gyfer ymchwilio tarddleuedd newydd dŵr daear
- “Parthau gwarchod tarddleuedd dŵr daear”
- “Digomisiynu dyfrdyllau a ffynhonnau diangen”
- “Mesur tynnu dŵr – Gwybodaeth ar gyfer dalwyr trwyddedau dyfrhau drwy chwistrellu”

### Arolygiaeth Dŵr Yfed (DWI)

- Cyfeirlyfr ar Drin Cyflenwadau Dŵr Preifat (1993)

### Y Weinyddiaeth Amaethyddiaeth, Pysgodfeydd a Bwyd (MAFF)

- Cyflenwadau Dŵr Fferm Taflen Rhif 1 – Gwarchod eich Cyflenwad Dŵr (Mawrth 1971)
- “Y Côt Dŵr” - Côt Ymarfer Amaethyddol Da er mwyn Gwarchod Dŵr (Hydref 1998)

### Awdurdod Gweithredol Iechyd a Diogelwch (HSE)

- Dogfen Wybodaeth HSE 847/4: Dyfrdyllau – Peryglon Dichonol o Ryddhad Methan (Gorffennaf 1990)

### Eraill

- Rheoliadau Dŵr Daear 1998 (SI NO.2746)
- Rheoliadau Ffrwyno Llygredd (Silwair, Slyri ac Olew Tanwydd Amaethyddol), 1991
- Rheoliadau Sefydliad y Perianwyr Trydanol (IEE), 16eg argraffiad
- Rheoliadau Rheoli Sylweddau sy’n Beryglus i Iechyd (COSHH), 1995
- Safon ar gyfer Ffynhonnau Cyflenwi Dŵr y Gymdeithas Gweithfeydd Dŵr Americanaidd (ANSI/AWWA A100-90)
- Monitro Cynnal ac Adfer Ffynhonnau Cyflenwi Dŵr, Adroddiad CIRIA 137
- BS 879 Rhannau 1 a 2, 1985 – casin ffynhonnau dŵr

## Troednodiadau

- 1 Mae gan adran Iechyd yr Amgylchedd yr Awdurdod Lleol gyfrifoldeb i sicrhau ansawdd cyflenwadau dŵr preifat, a phwerau i gondemnio tarddleuedd sy’n anaddas i’w hyfed.
- 2 Ble ceir caniatâd gan yr Asiantaeth i ymchwilio tarddle dŵr daear newydd byddwn yn gosod amodau penodol yng nghyswllt adeiladu unrhyw ddyfrdwl a gwneud profion, sy’n rhaid ymlynu wrthynt.
- 3 Mae amser teithio o 50 diwrnod neu lai yn cael ei fesur o unrhyw bwynt o fewn y parth ar, neu o dan, y lefel trwythiad.
- 4 Mae yna bosiblwydd bydd angen rheolaeth yn unol â’r Rheoliadau Dŵr Daear (1998) ar arllwysadau o elifion o danciau carthion sy’n agos at unrhyw ddyfrdwl sy’n cyflenwi dŵr yfed.
- 5 Mae’n ofynnol yn ôl y gyfraith i ddrilwyr roi gwybodaeth ymlaen llaw i’r Arolwg Daearegol Prydeinig o’u bwriad i ddrilio unrhyw dyllau turio sy’n fwy na 15 metr mewn dyfnder, ac i anfon cofn odion cwblhau atynt. Ni wneir hyn gan bob driliwr, a hyd yn oed os gwneir hyn ni fyddai staff lleol yr Asiantaeth o reidrwydd yn cael gwybod am darddleuedd newydd eu hadeiladu sy’n esgusodedig o orfod cael trwydded.
- 6 Dylid cynllunio cryfder y casin er mwyn iddo fod yn addas at gyflwr y tir a dyfnder y gosodiad.
- 7 Mae dur yn fwy caletsyth, yn gryfach a nid yw’n plygu.
- 8 Mae angen dyfrdwl gyda diamedr sy’n ddigon o faint o’r dechrau. Efallai bydd angen lleihadau oherwydd tir ansefydlog.
- 9 Efallai bydd angen casin eilaidd ychwanegol neu sgrîn rhychog wedi ei bacio â cherrig mân neu beidio, mewn acwifferau anghyfu nedig neu dir ansefydlog. Mewn achosion o ddyfrdyllau wedi eu drilio o dan ganiatâd ymchwiliad dŵr daear, gall yr Asiantaeth osod amod bod yn rhaid ynysu rhai adrannau.
- 10 Yn hanfodol os yw’r dyfrdwl yn artesiaidd.
- 11 Mae’n drosedd i ganiatâu i ddŵr artesiaidd fynd yn wastraff (Deddf Diwydiannau Dŵr 1991).
- 12 Darganfuwyd bod gan lawer o ddyfrdyllau wagle yng ngwaelod y casin parhaol. Mae hyn yn debygol o ddigwydd oherwydd growtio gwael neu oherwydd ni ddriliwyd yn ddigon dwfn i fewn i dir solet cyn gosod y casin parhaol.
- 13 Ble nad yw cwblhau ar yr wyneb yn bosibl.
- 14 Ni fydd suddfan ddŵr yn gweithio’n effeithiol os adeiladir siambr y twll archwiliad ar dir â hydredded isel neu yn is na’r lefel trwythiad.
- 15 Dylid ystyried defnyddio dau diwb dipio ble y bwriedir mesur lefel y dŵr â mesurydd llaw a chofnodydd data.
- 16 Awdurdod Gweithredol Iechyd a Diogelwch – “Dyfrdyllau - Peryglon Dichonol o Ryddhad Methan” HSE 847/4 Gorffennaf 1990. Os rhagwelir problemau â methan, yna dylid cysylltu â’r Awdurdod am gyngor.
- 17 Gall methan ddigwydd yn naturiol neu ddeillio o safleoedd tirlenwi neu darddleuedd eraill. Gall gollyngiadau naturiol ddigwydd o swlffid hydrogen a deuocsid carbon. Mae’r rhain yn medru bod yn berygl ble bod angen mynediad i bobl i le cyfyng.

## Other useful guidance

Other relevant guidance and regulations include:

### Environment Agency publications

- “Policy and Practice for the Protection of Groundwater” (1998). This sets out the Agency’s approach to managing and protecting groundwater.
- Pollution Prevention Guidelines, which give advice on certain potentially polluting activities:
  - PPG 2** - Above ground oil storage tanks
  - PPG 4** - Disposal of sewage where no mains drainage is available
  - PPG 8** - Safe storage and disposal of used fuel oils
  - PPG 9** - The prevention of pollution of Controlled Waters by pesticides
  - PPG 12** - The prevention of pollution of Controlled Waters by sheep dip
  - PPG 17** - Dairies and other milk handling operations
- “Searching for groundwater”, which explains the Agency’s requirements for investigating new groundwater sources
- “Groundwater source protection zones”
- “Decommissioning redundant boreholes and wells”
- “Metering abstractions - Information for spray irrigation licence holders”

### Drinking Water Inspectorate (DWI)

- Manual on Treatment of Private Water Supplies (1993)

### MAFF

- Farm Water Supply Leaflet No. 1 - Protecting your Water Supply (March 1971)
- “The Water Code” - Code of Good Agricultural Practice for the Protection of Water (October 1998)

### Health & Safety Executive

- Information Document HSE 847/4: Water Boreholes - Potential Hazard from Methane Evolution (July 1990)

### Others

- Groundwater Regulations 1998 (SI NO.2746)
- Control of Pollution (Silage, Slurry and Agricultural Fuel Oil) Regulations, 1991
- Institute of Electrical Engineers (IEE) Regulations, 16th Edition
- Control of Substances Hazardous to Health (COSHH) Regulations, 1995
- The American Water Works Association Standard for Water Wells (ANSI/AWWA A100-90)
- Monitoring Maintenance and Rehabilitation of Water Supply Wells. CIRIA Report 137
- BS 879 Part 1 and 2, 1985 - water well casing

---

## Footnotes

- 1 The Environmental Health department of the Local Authority has responsibility for checking the quality of private water supplies, and has powers to condemn sources unfit for human consumption.
- 2 Where the Agency issues consent to investigate a new groundwater source we will stipulate certain conditions relating to borehole construction and testing, which must be adhered to.
- 3 A travel time of 50 days or less is from any point within the zone at, or below, the water table.
- 4 Discharges of septic tank effluent close to any drinking water supply borehole may require control under the Groundwater Regulations (1998).
- 5 Drillers are required by law to give prior notification to the British Geological Survey of their intention to drill any boreholes over 15m deep, and to send completion records to them. Not all drillers do this, and even if they do local Agency staff would not necessarily be informed of newly constructed licence-exempt sources.
- 6 The casing strength should be designed to suit the ground conditions and installation depth.
- 7 Steel is more rigid, robust and does not bend.
- 8 Requires a large enough diameter borehole from the outset. Reductions may be necessary because of unstable ground.
- 9 Additional secondary casing or a slotted screen with or without a gravel pack may be required in unconsolidated aquifers or unstable ground. In the case of boreholes drilled under a groundwater investigation consent the Agency may stipulate that certain sections are sealed off.
- 10 Essential if the borehole is artesian.
- 11 It is an offence to allow artesian water to run to waste (Water Industries Act 1991).
- 12 Many boreholes have been found to have a cavity at the base of the permanent casing. This is likely to be due to poor grouting or not drilling deeply enough into solid ground before inserting the permanent casing.
- 13 Where an above ground completion is not possible.
- 14 A soakaway will not work effectively if the manhole chamber is constructed in low permeability ground or below the water table.
- 15 Two dip tubes should be considered where water level measurement is to be by manual dip meter and data logger.
- 16 Health & Safety Executive – “Water Boreholes – Potential Hazard from Methane Evolution” HSE 847/4 July 1990. If a methane problem is envisaged the HSE should be contacted for advice.
- 17 Methane can be found naturally or be derived from landfills or other sources. Hydrogen sulphide and carbon dioxide can be emitted naturally. These pose a potential hazard where man access is necessary into a confined space.

# ENGHREIFFTIAU O YMARFER GWael

## Cwblhau dan y ddaear

### YMARFER GWael

#### Allwedd i ffigur (d)

- A** - Ffrâm mewn concriid neu fetel sy'n cynnal caead y twll archwilio heb ei blannu ar sment neu briddgalch
- B** - Ôl-lenwi rhydd mandyllog (bydd briciau a rwbel y tu ôl i gylchoedd concriid yn annog mewnlif dŵr i siambr y dyfrdwl)
- C** - Cylchoedd concriid
- D** - Casin a chap y dyfrdwl wedi eu cwblhau yn rhy isel yn y siambr
- E** - Mewnlif dŵr
- F** - Caead y twll archwiliad o gryfder sy'n annigonol i ddal trafniadaeth gerbydol (os oes angen hyn)
- G** - Lefel y tir yn disgyn tuag at siambr y dyfrdwl
- H** - Cylchoedd concriid heb eu selio

- I** - Mewnlif dŵr
- J** - Plât metel crwn sy'n cynnal y pwmp wedi ei osod ar ben y casin slaes fras
- K** - Dim tiwb dipio
- L** - Mynediad i'r bibell gyflenwi heb ei selio
- M** - Dim ffos o'r siambr
- N** - Dim rendro gwrth-ddŵr tu fewn/tu allan i'r cylchoedd concriid (os nad ydynt yn ddwrglos yn naturiol)
- O** - Mewnlif dŵr i'r siambr trwy dwll cebl y pwmp neu drwy fylchau yn y casin slaes fras
- P** - Pibell ymgodol
- Q** - Dim growth tu ôl i gasin y dyfrdwl
- R** - Sylfaen concriid tenau

(d)

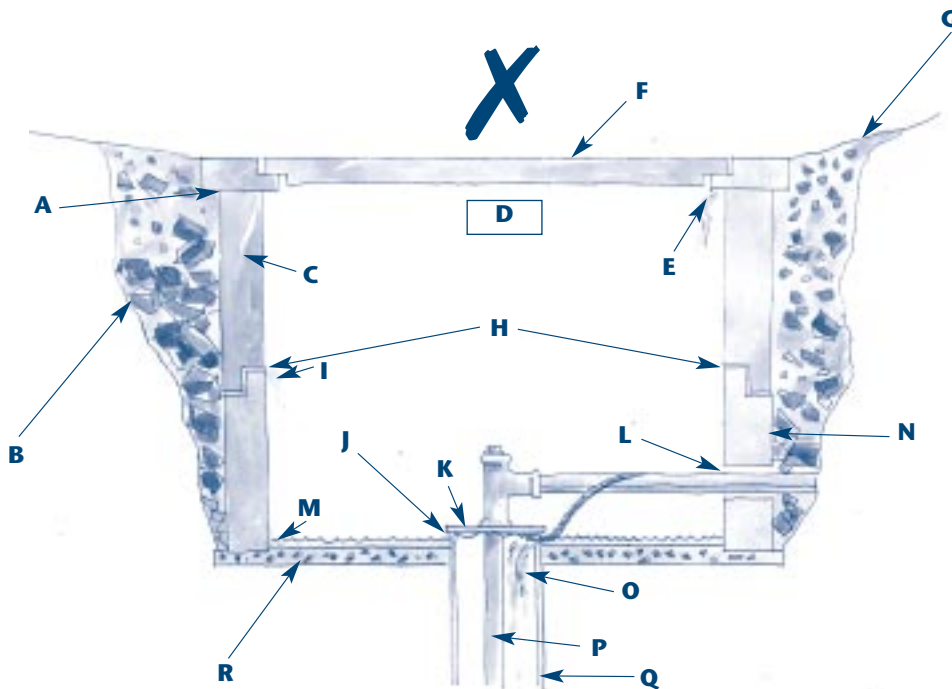

## EXAMPLES OF BAD PRACTICE

### Below ground completion

#### BAD PRACTICE

#### Key to figure (d)

- A** - Concrete or metal M/H cover support frame not bedded on cement or mortar
- B** - Porous loose backfill (bricks & rubble behind concrete rings will encourage ingress of water into borehole chamber)
- C** - Concrete rings
- D** - Borehole casing & cap finished off too low down in the chamber
- E** - Water ingress
- F** - M/H Cover of insufficient strength for vehicular traffic (if required)
- G** - Ground level falling towards BH chamber
- H** - Concrete ring joints not sealed
- I** - Water ingress

- J** - Round metal plate supporting pump installed on top of the rough cut casing
- K** - No dip tube
- L** - Delivery pipe access not sealed
- M** - No chamber drain
- N** - No waterproof rendering on the inside/outside of concrete rings (if not naturally waterproof)
- O** - Ingress of chamber water through pump cable hole or through the rough cut casing gaps
- P** - Rising main
- Q** - No grout behind borehole casing
- R** - Thin concrete base

# ENGHREIFFTIAU O YMARFER GWael

## Gollyngiad Peryglus

ENGHREIFFTIAU O YMARFER GWael YNG NGHYSWLLT  
CWBLHAU BLAENWAITH A CHADW CEMEGAU GER DYFRDYLLAU

### Allwedd i ffigur (e)

- A** - Pibell ymgodol
- B** - Cebll ynni i'r pwmp suddadwy
- C** - Clamp y bibell ymgodol
- D** - (Wedi ei dorri ymaith yn rhy agos i lefel y llawr)
- E** - Casin y dyfrdwl
- F** - Tiwb dipio

(e)

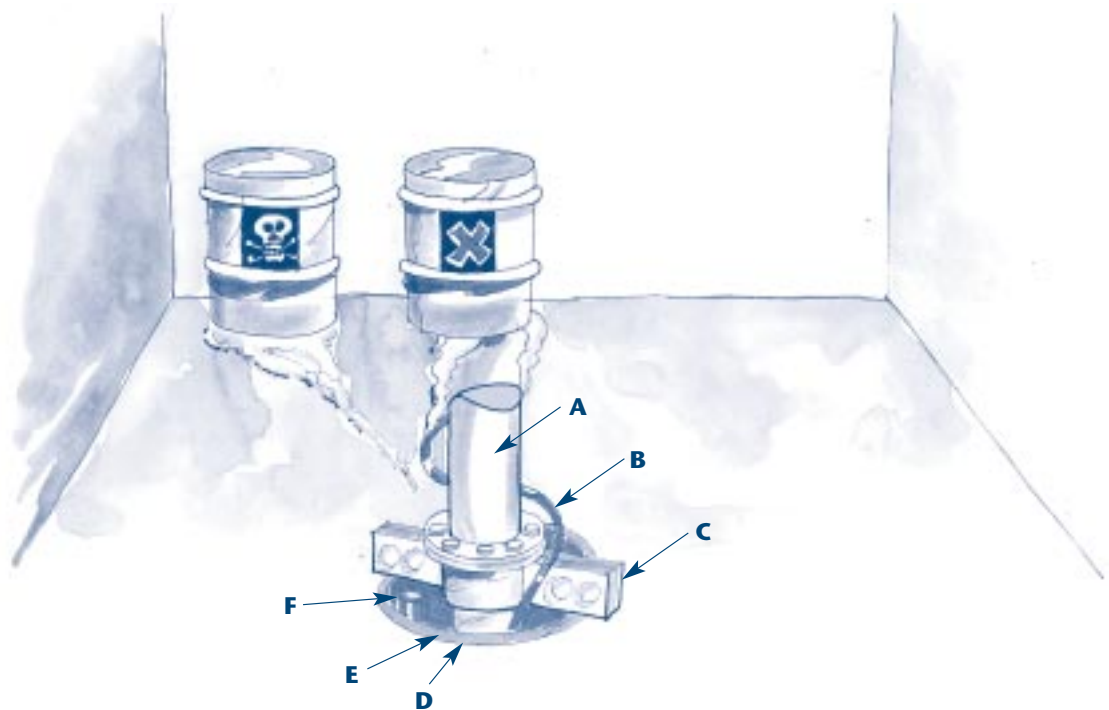

## EXAMPLES OF BAD PRACTICE

### Hazardous spill

EXAMPLE OF BAD PRACTICE OF HEADWORKS COMPLETION  
& CHEMICAL STORAGE NEAR TO BOREHOLES

### Key to figure (e)

- A** - Rising-main
- B** - Power cable to submersible pump
- C** - Rising-main clamp
- D** - (Cut off too close to floor level)
- E** - Borehole casing
- F** - Dip-tube



ASiantaeth yr Amgylchedd

**PENCADLYS**

Rio House  
Waterside Drive  
Aztec West  
Almondsbury  
Bryste BS32 4UD  
Ffôn: 01454 624400  
Ffacs: 01454 624409  
www.asiantaeth-amgylchedd.gov.uk

ENVIRONMENT AGENCY

**HEAD OFFICE**

Rio House  
Waterside Drive  
Aztec West  
Almondsbury  
Bristol BS32 4UD  
Tel: 01454 624400  
Fax: 01454 624409  
www.environment-agency.gov.uk

ASiantaeth yr Amgylchedd Cymru

**SWYDDFA CYMRU**

Plas-yr-Afon  
Parc Busnes Llaneirwg  
Heol Fortran  
Llaneirwg  
Caerdydd CF3 0EY  
Ffôn: 029 2077 0088  
Ffacs: 029 2079 8555  
www.asiantaeth-amgylchedd.cymru.gov.uk

ENVIRONMENT AGENCY WALES

**WALES OFFICE**

Rivers House  
St Mellons Business Park  
Fortran Road  
St Mellons  
Cardiff CF3 0EY  
Tel: 029 2077 0088  
Fax: 029 2079 8555  
www.environment-agency.wales.gov.uk

CANOLFAN GENEDLAETHOL Dŵr DAear a Thir Wedi'i Lygru/  
NATIONAL GROUNDWATER & CONTAMINATED LAND CENTRE

Olton Court, 10 Warwick Road,  
Olton, Solihull B92 7HX  
Ffôn/Tel: 0121 711 5885  
Ffacs/Fax: 0121 711 5925  
E-bost/E-mail: ngwclc@environment-agency.gov.uk

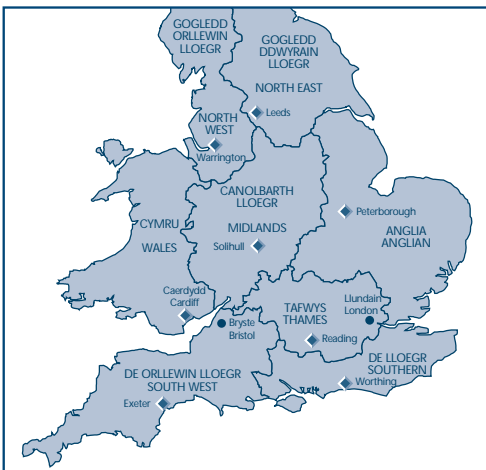
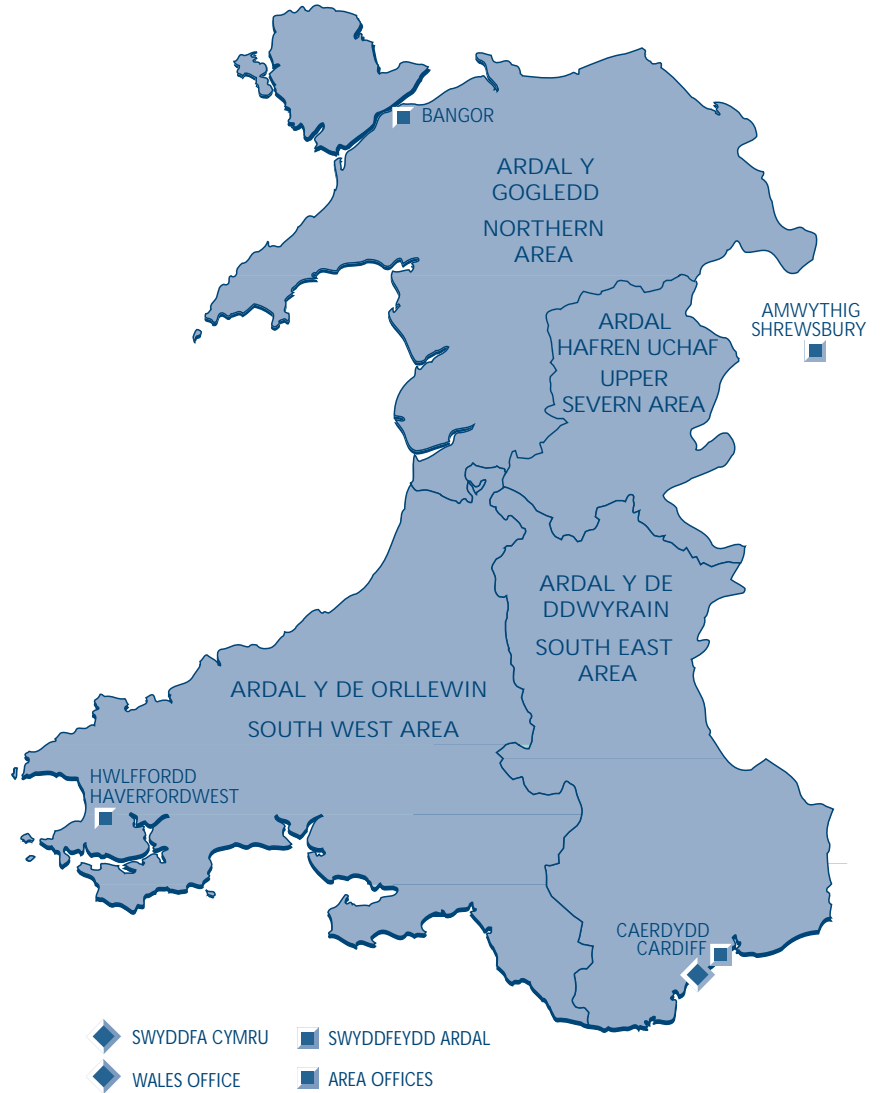

YMHOLIADAU CYFFREDINOL ASiantaeth yr Amgylchedd  
ENVIRONMENT AGENCY GENERAL ENQUIRY LINE

**0845 933 3111**

LLINELL LLIFOGYDD ASiantaeth yr Amgylchedd  
ENVIRONMENT AGENCY FLOODLINE

**0845 988 1188**

LLINELL ARGYFWNG ASiantaeth yr Amgylchedd  
ENVIRONMENT AGENCY EMERGENCY HOTLINE

**0800 80 70 60**



ASiantaeth yr Amgylchedd Cymru  
ENVIRONMENT AGENCY WALES



**Canolfan Genedlaethol Dŵr  
Daear a Thir Llygredig**

**National Groundwater and  
Contaminated Land Centre**



## **Gwneuthuriad Dyfrdyllau Cyflenwi Dŵr a Blaenwaith**

*CANLLAWIAU AR GYFER YMARFER DA*



## **Water Supply Borehole Construction and Headworks**

*GUIDE TO GOOD PRACTICE*



**ASiantaeth yr  
Amgylchedd Cymru  
Environment  
Agency Wales**